



Environmental Products



pumps

The Self-venting Submersible Electric Pump is an economical and effective way of pumping shallow wells (less than 18 m or 60 ft). The unit is completely sealed, designed to be powered by a 12 V battery and can fit in a 50 mm (2 in.) inside diameter well. The price and portability of this pump makes it a popular choice for purging ground water wells prior to environmental sampling.

stainless steel screen pre-pack filtration products

RST's Stainless Steel Screen Pre-Pack is ideal for use with direct push drill technology for small diameter monitoring wells. The Stainless Steel Screen Pre-Pack is developed to keep pace with the ever increasing use of cost effective direct push technology. The high open area of the "Pre-Pack" cuts sampling time in low-yield wells and the tight packed sand filter reduces turbidity in the well.

pre-pack filtration specs

ITEM	SPECIFICATION
Outside Diameter	35.56 mm (1.4 in.)
Total Length	1524 mm (60 in.)
Screen Island Length	1371.6 mm (54 in.)
3/4 in. PVC (schedule 40) Inner Diameter	20.93 mm (.824 in.)
Sand sizes	Upon request

environmental equipment for rental

ITEM	DAILY RATE	WEEKLY RATE	MONTHLY RATE
PUMPING			
Peristaltic Pump (12 V power supply required)	\$60.00	\$120.00	\$360.00
Waterra Power Pump (Gas powered, supplied on cart, approx 100 lbs.)	100.00	320.00	715.00
WATER LEVEL MONITORING			
Water Level Meter 30 m Polyethylene coated	50.00	55.00	115.00
Water Level Meter 300 m Polyethylene coated	50.00	165.00	325.00
Water Level Meter 30 m / 100 ft. (dual scale) Polyethylene coated	50.00	65.00	130.00
Water Level Meter 30 m / 100 ft. (dual scale) Tefzel™ coated	50.00	90.00	185.00
Water Level Meter 100 ft. Polyethylene coated	50.00	55.00	115.00
Water Level Meter 200 ft. Polyethylene coated	50.00	90.00	180.00
Water Level Meter 210 ft. Polyethylene coated	50.00	90.00	180.00
Oil/Water Interface Probe - 30 m	75.00	186.00	410.00
BH1000 DataTrapper Automatic Water Level Logger (5 - 100 psi range)	150.00	250.00	650.00
BH1044 Multi Channel Logger for Vibrating Wire Sensors	75.00	250.00	650.00
WATER QUALITY MONITORING			
Multi-Parameter - Hanna (pH, temperature, conductivity, TDS)	75.00	150.00	350.00
Dissolved Oxygen Meter - Hanna (waterproof)	50.00	100.00	250.00

Rental availability based on first come, first serve.

All damage, related to the use by clients of rental equipment, is the responsibility of the client to pay for repairs or replacement. Rental prices may change without notice.

Additional items will be available in the future, so please call RST Instruments for updates. All prices quoted are FOB Coquitlam, excluding applicable taxes. Subject to RST Standard Terms & Conditions.



RST Instruments Ltd.
200 - 2050 Hartley Ave.
Coquitlam, BC
Canada V3K 6W5

Telephone: 604 540 1100
Facsimile: 604 540 1005
Toll Free: 1 800 665 5599



info@rstinstruments.com

www.rstinstruments.com

pump applications

- Pumping shallow wells.
- Purging ground water wells prior to environmental sampling.

pump features

- Lightweight.
- Powered by a 12 V battery.
- Available in either 12 m (40 ft) or 18 m (60 ft) lengths.
- Will pump turbid water.
- Suitable for 50 mm (2 in.) inner diameter wells or larger.
- 13 mm nipple supplied to convert outlet nipple from 10 mm.
- Can be used in water temperature up to 60°C.

pump models

ITEM	PART #
Mini Purger	EPWP040
Super Purger	EPWP060

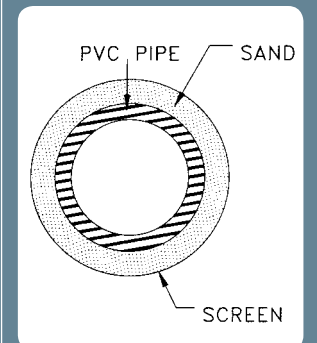

Cross-section drawing of a Screen Pre-Pack

Tefzel® is a registered trademark of E. I. du Pont de Nemours and Company or its affiliates. RST Instruments Ltd. reserves the right to change specifications without notice.